

http://www.tutu.com/meascht_womens_instr.html

Women's Measurement Chart - Body Form #1

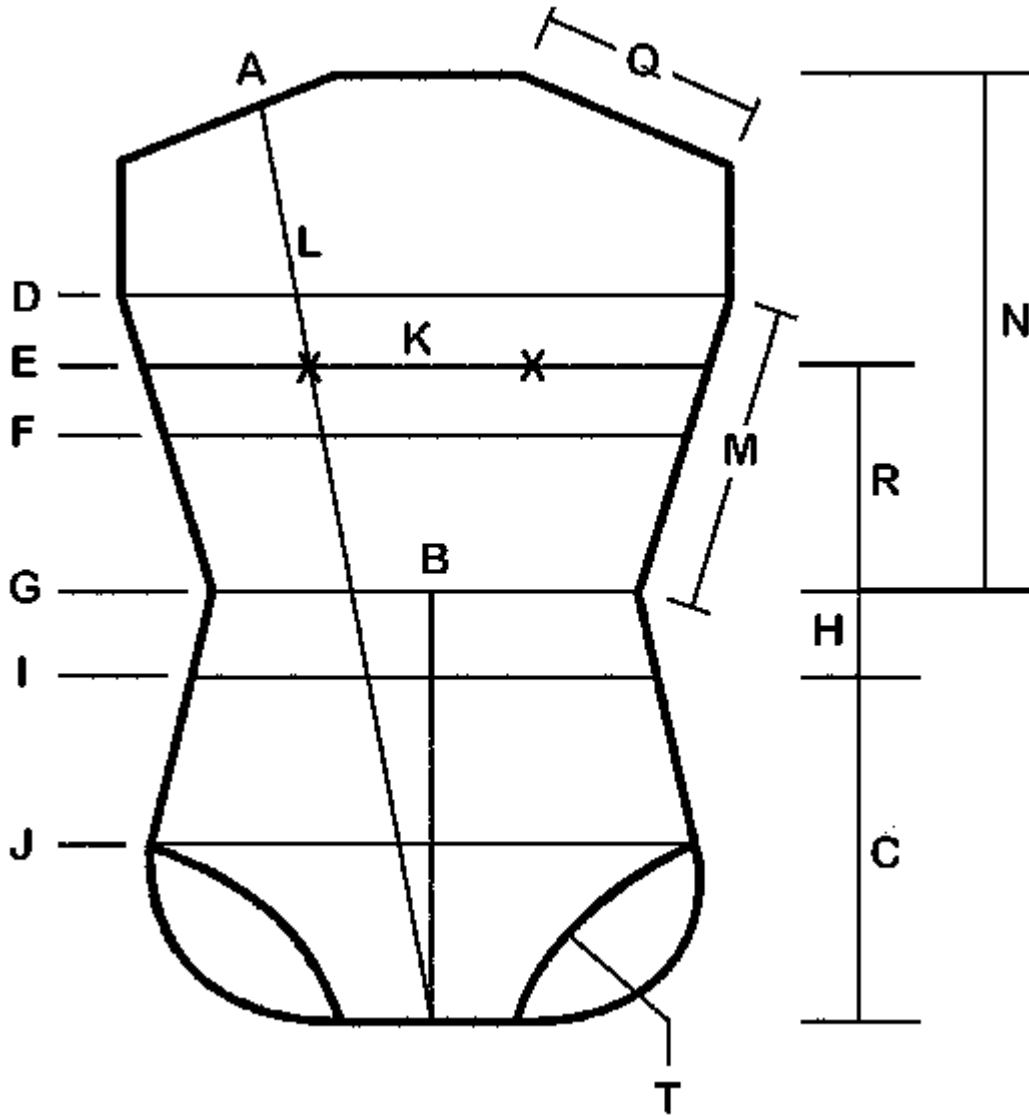

continued on next page

Women's Measurement Chart

Instructions for Use

Notice: These instructions, charts, and Body-Forms are copyrighted material, and are intended solely for the use by customers of Tutu.Com who are ordering costumes or dancewear from us, attending our seminars, or otherwise need to send us measurements. Any other use is a direct violation of US and international copyright laws.

Use your Browser's BACK BUTTON to return to the last page you were viewing, or use the [Text Links Below](#) to visit elsewhere on our website.

First, a Major Caveat!

Our costumes and garments are constructed based on measurements YOU provide. Tutu.Com is NOT responsible for incorrect fit if the measurements are not taken correctly! We will NOT refund any portion of the cost of your costume or garment if incorrect measurements are provided to us.

You are probably spending a lot of money - we highly recommend having a professional seamstress, fitter, or alterationist take the measurements if necessary. In some cases, we may be able to alter or re-fit a costume or garment that was based on incorrect measurements - *note that you will incur additional charges for this service.* In other cases, alterations may not be possible, *and will require that you purchase a new costume or garment to be constructed from new measurements!*

In general, we will nearly always need all measurements listed through to Item 'T'.

If we are creating a headpiece, please provide the 'head' measurements.

For dresses, unitards, and other items, we'll need some or all of the additional measurements, as appropriate to the particular garment we're creating. Call or email if you have questions regarding which measurements to take for your particular costume or garment.

Tip #1: Tie a piece of string (snug but not tight) around the waist (at Line-G). Use the string as your measuring line. (String works better than elastic because it will tend to 'drape' or fall to the 'natural' waist line, whereas elastic will tend to create a 'false' waistline.)

Tip #2: All measurements should be in US units (inches, pounds, etc.)

- divide centimeters by 2.54 to convert to inches
- multiply kilograms by 2.2 to convert to pounds

Tip #3: *Don't* allow the dancer to provide her own measurements. If necessary, have a professional seamstress, fitter, or alterationist take them – with only 1/2-inch of ease in most seams, there's no room

for error!

***** CORRECT MEASUREMENTS ARE OF THE UTMOST IMPORTANCE! *****

Having fit thousands of dancers over the years, we know when a particular measurement or combination of measurements doesn't seem right. We will contact you to ask for a re-measure if necessary.

As always, please feel free to call or email us if you are unsure of, or have any questions regarding, which measurements to take or how to take them. See the [How to Contact Us](#) page for all the ways to get in touch with us.

The Measurements Chart is broken into 3 sections: a printable measurement chart, a printable bodyform drawing, and an emailable measurement chart. We recommend you print the [Printable Measurement Chart](#) and the [BodyForm](#). Use these to take your measurements. You can then mail or fax to us the Measurements Chart page. Or you can return to this site, and email us your measurements using the [Emailable Measurements Chart](#).

You should also print this Instructions page for your information and records.

If you mail or fax:

We need only the Measurements page - no need to mail or fax us this Instructions page or the Body Form drawing page.

Once complete, you can mail the Measurements page to:

Tutu.Com, Inc.
PO Box 472287
Charlotte, NC 28247-2287 United States

or, fax the Measurements page to (+)1.704.542.1564.

Click on the links below to print or email the appropriate pages:

[\[Printable Measurement Chart\]](#) [\[Printable BodyForm\]](#) [\[Emailable Measurement Chart\]](#)

The entire **Women's Measurement Chart Package** is also available for download as a PDF Document. You MUST have (the free) Adobe Acrobat Reader installed to view or print this file. If you don't have the Acrobat Reader, you can download and install it directly from the [Adobe website](#) at www.adobe.com.

[Click Here to Download the PDF version of the Women's Measurement Chart Package](#)